

QF18 Miniature Circuit Breaker & QF10 RCBO



QF18
Miniature Circuit
Breaker



QF18
Miniature Circuit
Breaker



QF10 RCBO
(Neutral pigtail not shown)



QF10 RCBO
with handle lock

Features

- Precision circuit breaker utilizing hydraulic magnetic technology
- DIN mounting
- Always carry 100% of rated current. Trip point un-affected by ambient temperature
- Mid-trip handle indication signifies breaker operation for electrical fault
- Immediate resetting can be done after clearance of fault (No thermal memory)
- No ageing deterioration of sensing mechanism which is hermetically sealed
- IP2X terminals
- Handle is sealable and padlockable (with padlock attachment)
- Suits HQFC chassis - 250A rated
- RCBO is suitable for applications with pulsating DC components
- RCBO insulation resistance testing can be done with handle in the off position - no disconnection of the unit is required

Applications

The QF range of MCB's and RCBO's are for use against overload, short circuit and residual current (QF10 only) protection in residential, commercial, industrial and mining applications.

QF18 Miniature Circuit Breaker & QF10 RCBO

Technical Data

Product Type	QF18	QF10
Equipment Type	MCB	RCBO
Standards	AS 3111	AS/NZS 3190
Approval Number	NSW22415	NSW21009
Number of Poles	1, 2 & 3	1
Rated Breaking Capacity (Icu)	6kA at 240/415V AC	6kA at 240V AC
Standard Ampere Rating (A)	2, 4, 6, 10, 16, 20, 25, 32, 40, 50, 63 A	6, 10, 16, 20, 25, 32, 40 A
Residual Operating Current (mA)	N/A	30mA
Rated Voltage (V)	240V/415V	240V (110V-240V operating voltage)
Frequency (Hz)	50-60Hz	50-60Hz
Impulse Withstand Voltage (kV)	6kV	6kV
DC Withstand Voltage	600V DC	600V DC
Mechanism	Hydraulic Magnetic	Hydraulic Magnetic & RCD
Tripping Curves	1, 2 & 3	2
Handle Colour	Curves 2 & 3: White, Curve 1: Orange	Curve 2: White
Terminal Configuration	Front connected box type	Front connected box type
Max Conductor Size	25mm ² (line & load)	25mm ² (line), 16mm ² (load)
Terminal Torque	2.5Nm	2.5Nm

Dimensional Details

QF18 - MCB

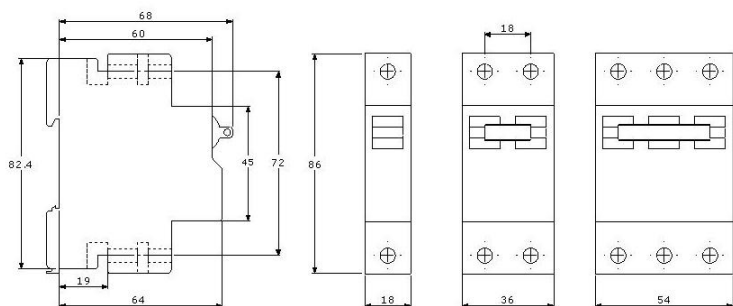

QF10 - RCB

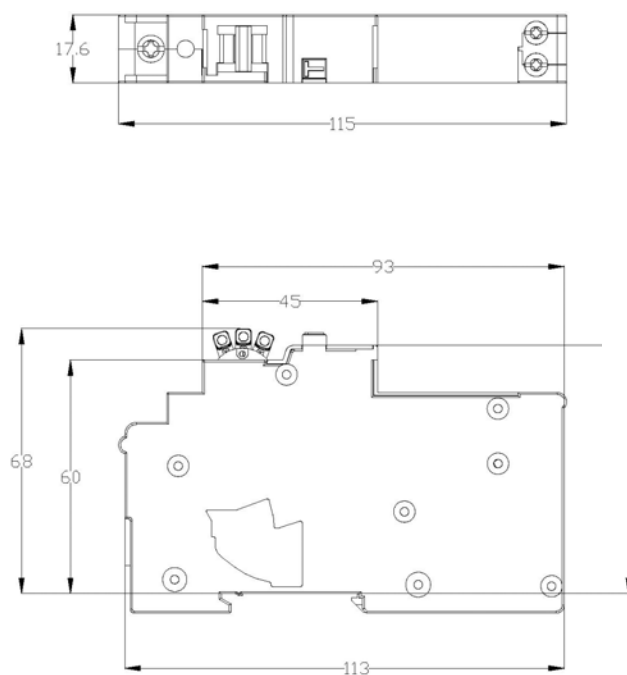

Note: All dimensions are in mm.

QF18 Miniature Circuit Breaker

Technical Data

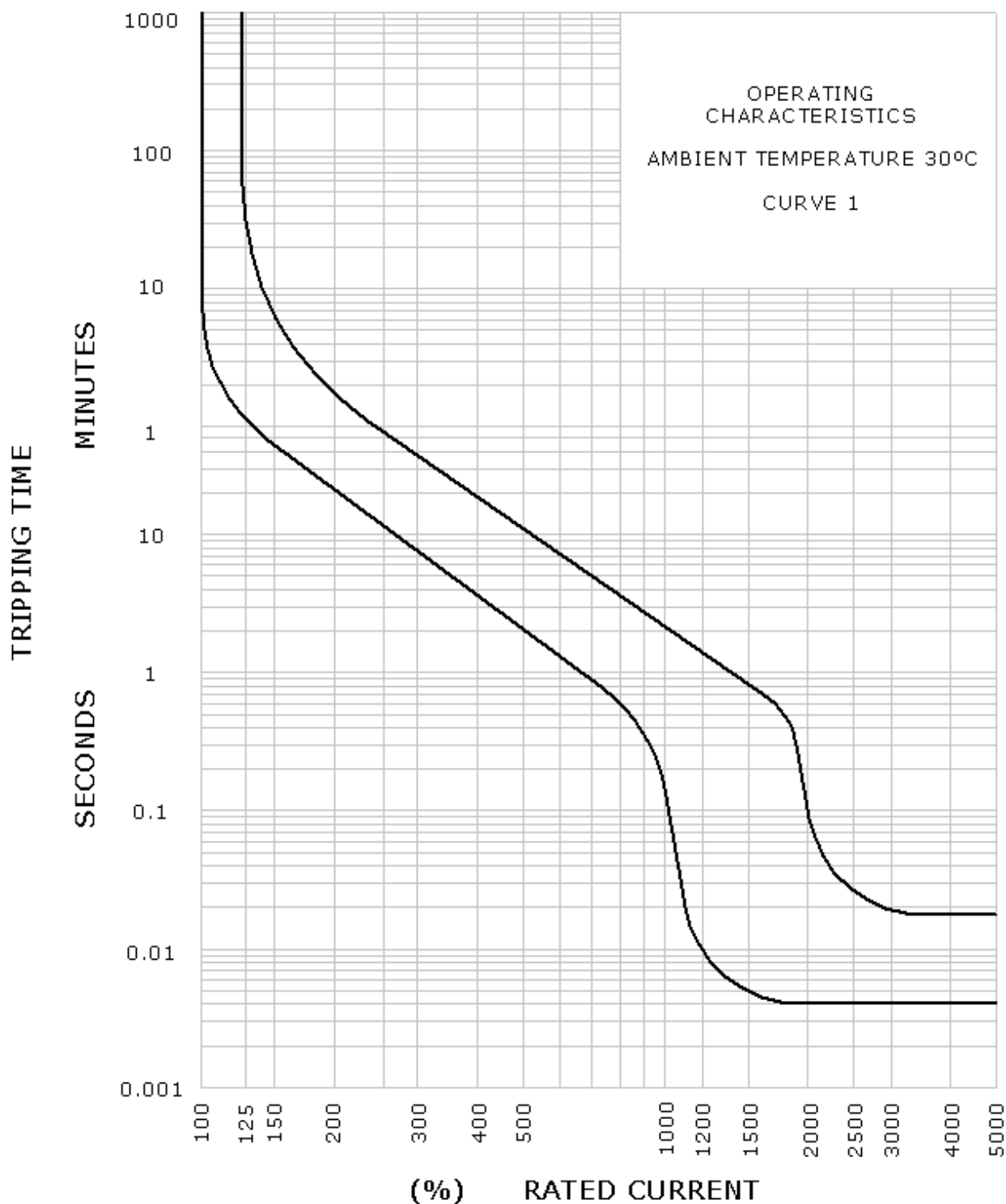

Note: Curve I is similar to Curve D. Used for motor starting and transformer applications.

QF18 Miniature Circuit Breaker & QF10 RCBO

Technical Data

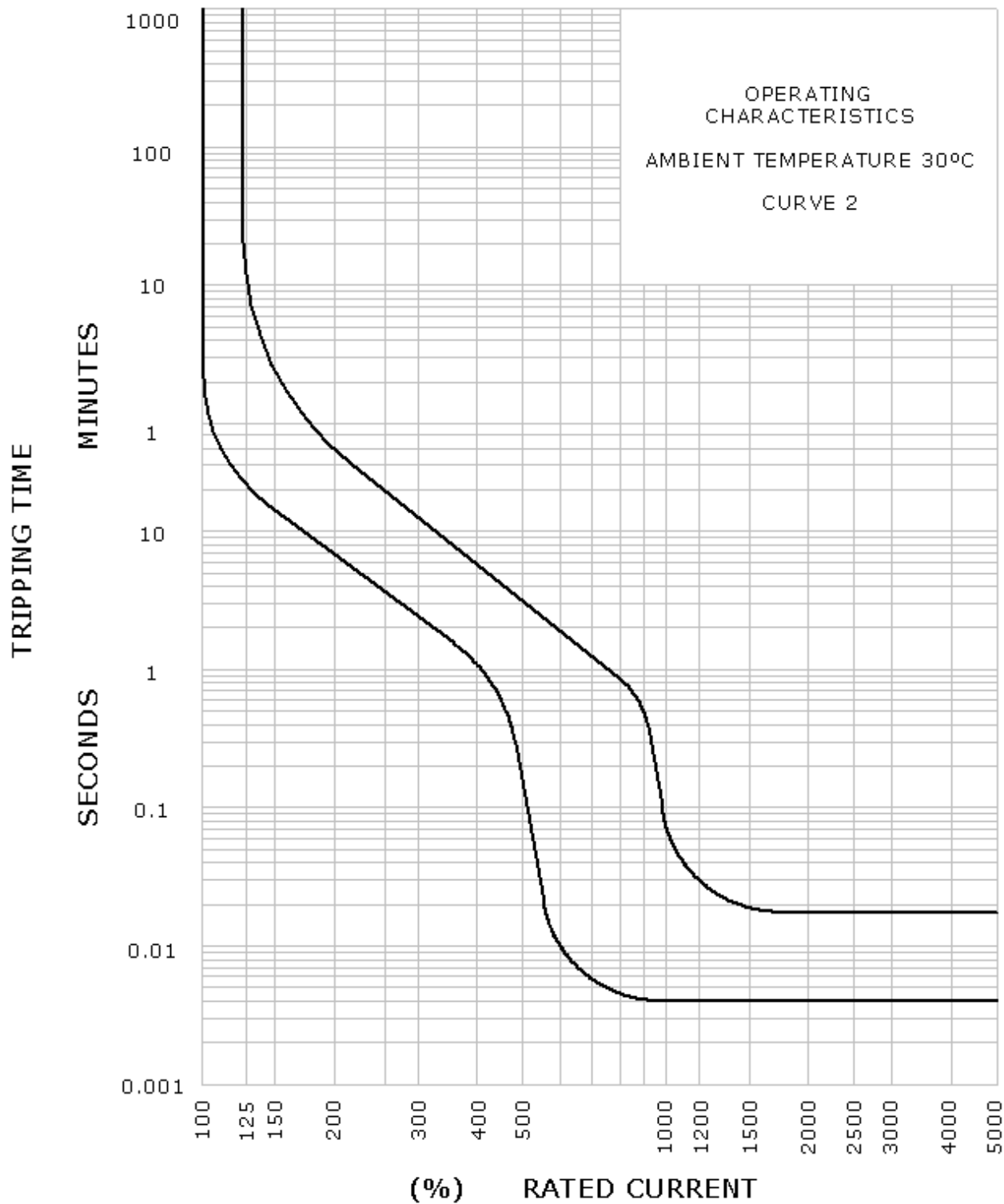

Note: Curve 2 is similar to Curve C. Used for general lighting and power applications.

QF18 Miniature Circuit Breaker

Technical Data

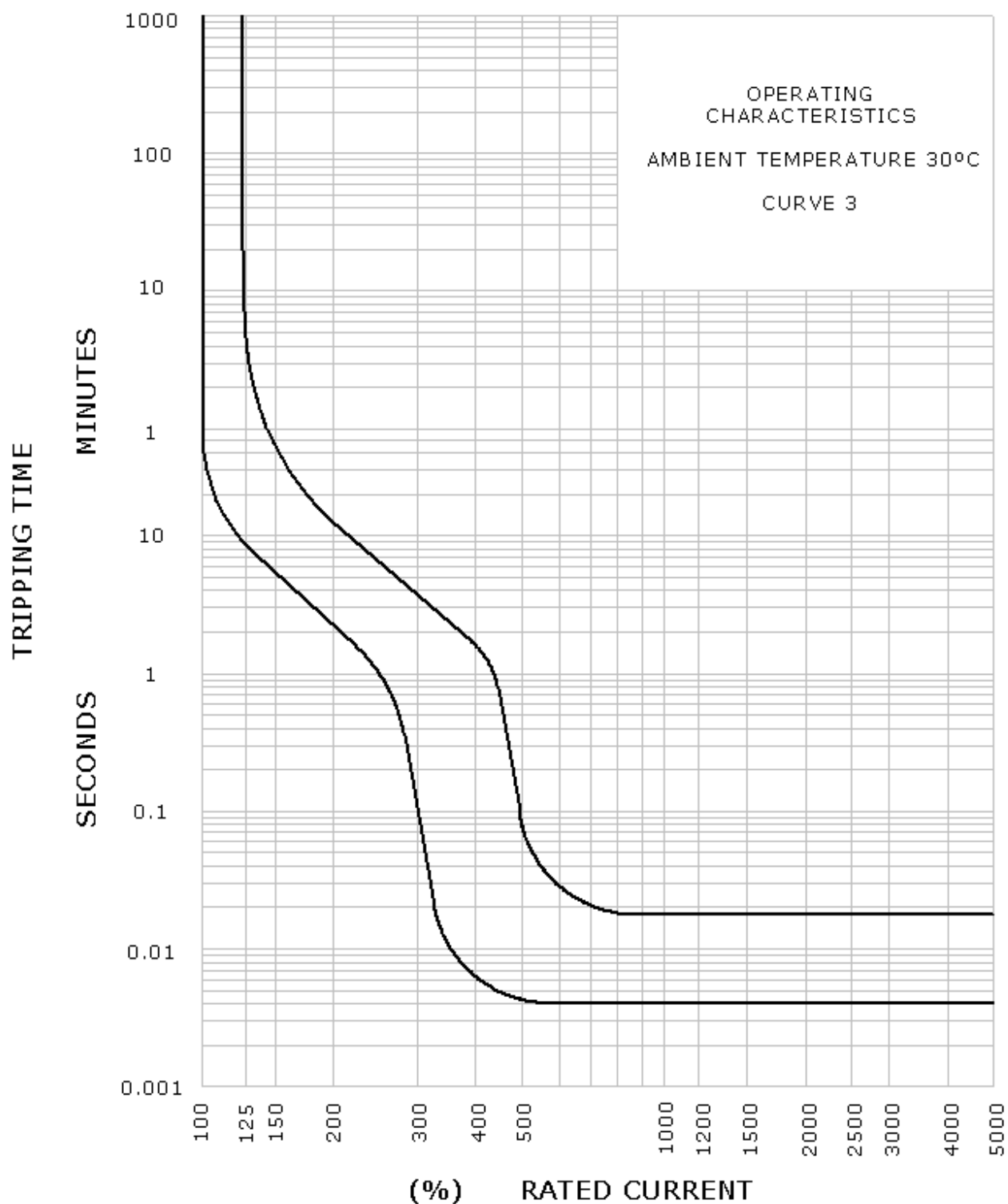

Used for applications where inrush currents do not exceed $3-5 \times I_n$.

QFI8 Miniature Circuit Breaker & QFI0 RCBO

Motor Circuit Protection

240V, 50Hz, SINGLE PHASE			
Full Load Current (A)	Approx. Motor kW	Amp Rating	Approx. Motor h.p.
1.8	0.12	6	1/6
2.7	0.18	6	1/4
3.0	0.25	6	1/3
4.0	0.37	10	1/2
5.2	0.55	10	3/4
6.3	0.75	10	1
8.0	1.1	16	1-1/2
10.0	1.5	16	2
14.5	2.2	20	3
18.5	3.0	32	4
24.0	3.7	40	5
33.0	5.5	50	7-1/2

415V, 50Hz, THREE PHASE				
Full Load Current (A)	Approx. Motor kW	D.O.L. (Amp Rating)	Star-Delta (Amp Rating)	Approx Motor h.p.
1.5	0.55	6	4	
2.0	0.75	6	6	1
3.0	1.1	6	6	1-1/2
4.0	1.5	10	10	2
5.0	2.2	10	10	3
7.0	3.0	16	10	4
8.0	3.7	16	16	5
9.0	4.0	20	16	6
10		20	16	
11	5.5	20	16	7-1/2
12		20	16	
13		25	20	
14		25	20	
15	7.5	25	20	10
16		25	25	
17-20	10	32	32	12-1/2
21-22	11	32	32	15
23-26		40	40	
27-28	15	40	40	20
29-31		50	50	
32-36	18.5	50	50	25
37-44	22	63	63	30

QF18 Miniature Circuit Breaker & QF10 RCBO

Part Number Details

QF18 MCB*						
Ampere Rating	Curve 2 (Standard)			Curve I		
	1 Pole	2 Pole	3 Pole	1 Pole	2 Pole	3 Pole
2	QFD18202	QFD28202	QFD38202	QFD18102	QFD28102	QFD38102
4	QFD18204	QFD28204	QFD38204	QFD18104	QFD28104	QFD38104
6	QFD18206	QFD28206	QFD38206	QFD18106	QFD28106	QFD38106
10	QFD18210	QFD28210	QFD38210	QFD18110	QFD28110	QFD38110
16	QFD18216	QFD28216	QFD38216	QFD18116	QFD28116	QFD38116
20	QFD18220	QFD28220	QFD38220	QFD18120	QFD28120	QFD38120
25	QFD18225	QFD28225	QFD38225	QFD18125	QFD28125	QFD38125
32	QFD18232	QFD28232	QFD38232	QFD18132	QFD28132	QFD38132
40	QFD18240	QFD28240	QFD38240	QFD18140	QFD28140	QFD38140
50	QFD18250	QFD28250	QFD38250	QFD18150	QFD28150	QFD38150
63	QFD18263	QFD28263	QFD38263	QFD18163	QFD28163	QFD38163

* Curve 3 details available upon request

QF10 RCBO	
Ampere Rating	Part Number Details
6	QF10A206
10	QF10A210
16	QF10A216
20	QF10A220
25	QF10A225
32	QF10A232
40	QF10A240

Principles of Operation of Hydraulic-Magnetic Circuit Breakers

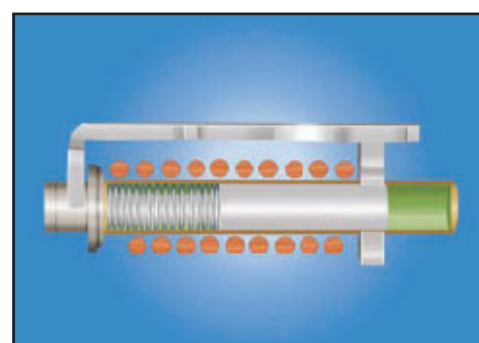
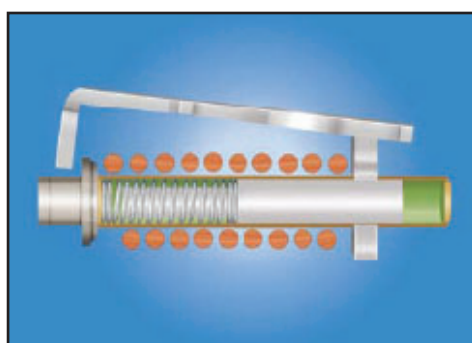
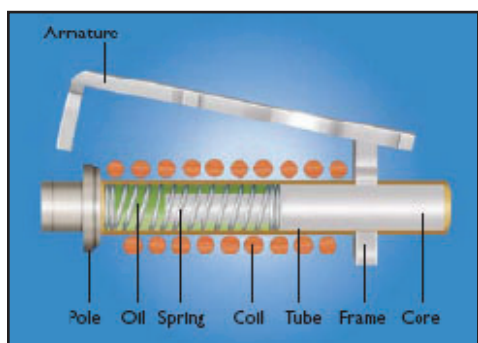

Overload 1

Load current flows through a series connected solenoid coil around a tube which contains an iron core, a spring and dampening fluid.

Only where current above circuit breaker rating occurs does the magnetic flux in the solenoid coil generate sufficient pull on the iron core to move it toward the pole piece.

Overload 2

Whilst this movement is in progress the dampening fluid regulates the speed of travel of the iron core thereby controlling time delay.

Time delay is important in that if overload is of short duration the core returns to its rest position once the overload disappears.

Overload 3

If overload persists the core will reach the pole piece after a time delay particular to that current and in so doing the reluctance of the magnetic circuit drops and the armature will be attracted to the pole piece with sufficient force to trip the mechanism.

The contacts separate, current ceases to flow and the core returns to its rest position.

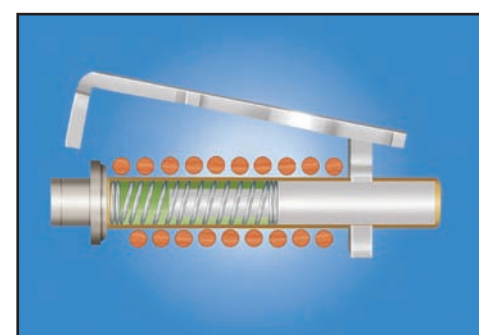
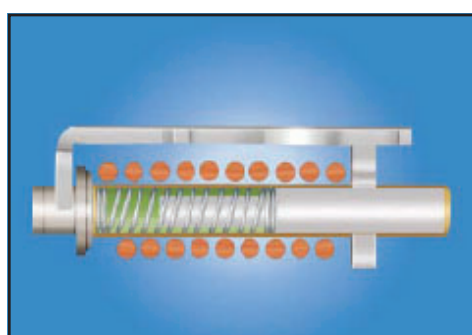
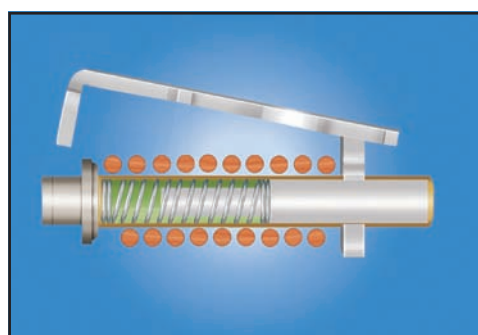

Short Circuit 1

Load current produced by magnetic force flows through series connected solenoid coil around a tube which contains an iron core, a spring and dampening fluid.

Short Circuit 2

With high values of overload or short circuit the magnetic flux produced by the coil is sufficient to attract the armature to the pole piece and trip the breaker without the iron core moving (instantaneous trip region).

Short Circuit 3

After tripping the circuit breaker may be reclosed immediately once fault has been cleared as there will have been no build up of heat and therefore no cooling down period required.

HEAD OFFICE

Melbourne

Tel: +61 9560 3522 Fax: +61 9562 0420 Email: heinelec@heinelec.com.au Website: www.heinemannelectric.com.au

SALES OFFICES

Southern Region (VIC & SA)

Tel: +61 3 9560 3333
Fax: +61 3 9562 0172
Email: sales@heinelec.com.au

Sydney

Tel: +61 2 9808 3000
Fax: +61 2 9809 6296
Email: hesyd@heinelec.com.au

Newcastle

Tel: +61 2 4952 6653
Fax: +61 2 4952 5020
Email: heneu@heinelec.com.au

Brisbane

Tel: +61 7 3279 1833
Fax: +61 7 3279 1866
Email: hebri@heinelec.com.au

Townsville

Tel: +61 7 4775 5300
Fax: +61 7 4725 1029
Email: hetow@heinelec.com.au

Perth

Tel: +61 8 9478 3341
Fax: +61 8 9478 3501
Email: heper@heinelec.com.au

AGENTS

Hobart - Electrical Agencies

Tel: +61 3 6273 1855
Fax: +61 6273 1158
Email: elecag@bigpond.net.au

Darwin - Jewell Distributors Pty Ltd

Tel: +61 8 8947 0870
Fax: +61 8 8947 0764
Email: jewell.distributors@bigpond.com